

WILKINS® Backflow Prevention

375 Series RPZ

15-25mm

Installation, Testing & Maintenance

CAUTION: Installation of Backflow Preventers must be performed by qualified, licenced personnel. The installer should be sure the proper device has been selected for the particular installation. Faulty installation could result in an improperly functioning device.

WILKINS Model 375 Reduced Pressure Principle Backflow Preventers are for use on water lines where a health hazard could exist if a backflow situation were to occur.

Proper performance is dependent upon following these installation instructions and prevailing governmental and industry standards and codes. Failure to do so, according to WILKINS Limited Warranty "...releases WILKINS of any liability that it might otherwise have with respect to that device." Such failure could also result in an improperly functioning device.

Damage to the device could result wherever water hammer and/or water thermal expansion could create excessive line pressure. Where this could occur, shock arresters and/or pressure relief valves should be installed downstream of the device.

1. Before installing a Model 375 Backflow Preventer, flush the line thoroughly to remove all debris, chips and other foreign matter. If required, a strainer should be placed upstream of the Backflow Preventer.

CAUTION: Do not use a strainer in seldom used emergency waterlines such as fire lines.

2. Provide adequate space around the installed unit so that the test cocks will be accessible for testing and servicing.
3. **WARNING:** If installation of a Model 375 is in a building, a suitable drain arrangement **MUST** be provided to drain off spillage from the relief valve. (Refer to "relief valve discharge" table below). An air gap at least two times the pipe diameter must be provided between the relief valve and the drain piping to prevent a cross-connection.

CAUTION: Do not pipe the relief valve solidly to a floor drain, sewer or sump.

4. Install valve at least 305mm above surrounding flood level.
5. Always consult local codes for installation methods, approvals and guidance.

OUTDOOR INSTALLATION

Model 375 Backflow Preventers may be installed outdoors only if the device is protected against freezing conditions. Exposure to freezing conditions will result in improper function or damage to the device. The installation location must be kept above 0°C. All the basic installation instructions apply.

If installation is in a pit or vault, the Backflow Preventer must never be submerged in water because this will cause a cross-connection. Make sure that the pit or vault always remains dry by providing ample drainage.

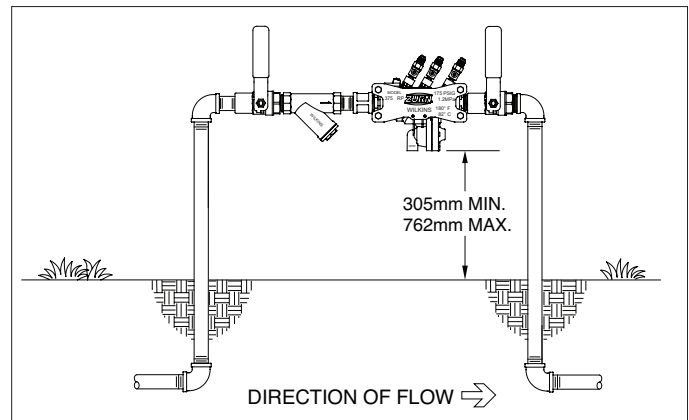

INDOOR INSTALLATION

Indoor installation is preferred in areas that are subject to freezing conditions. All the basic installation instructions apply to such installations.

PARALLEL INSTALLATION

Where uninterrupted service from a single meter connection must be maintained, two or more Backflow Preventers may be connected in parallel. All the basic installation instructions apply to parallel installation. Be sure to allow adequate room between the units for testing and repair.

PLACING THE DEVICE IN SERVICE

After the installation of a Model 375 has been completed, place the unit in service as follows:

375 REDUCED PRESSURE PRINCIPLE

1. Start with both shut-off valves closed. Slowly open the inlet shut-off valve until the backflow preventer is completely pressurised. A brief discharge from the relief valve may occur while the device is pressurizing. The discharge should cease by the time the shut-off valve is fully open. Device should function properly. If the discharge does not stop, refer to "MAINTENANCE INSTRUCTIONS" for repair procedures.
2. After the device has been pressurised, vent all trapped air from both check valves by slightly opening each of the three test cocks.
3. Slowly open the downstream shut-off valve. The Model 375 Reduced Pressure Principle Backflow Preventer is now in service.
4. If "spitting" or intermittent discharges from the relief valve are noted, it could be a result of pressure fluctuation and/or a water hammer condition in the system. If such conditions exist, install a WILKINS water pressure reducing valve, a check valve, or a water hammer shock arrester in compliance with industry standards as needed.
5. After the Model 375 has been properly installed, test the device (see "TEST PROCEDURES"). If the device fails the test, remove the first and second check valves and thoroughly flush the device. If the relief valve fails to operate properly, inspect the sensing passage for clogging (see "MAINTENANCE INSTRUCTIONS"). Clean rubber seals of all debris and place unit back in service.

Testing Procedures

MODEL 375 REDUCED PRESSURE PRINCIPLE ASSEMBLY

Equipment Required: Differential pressure gauge test kit.

TEST NO. 1

Purpose:

Test #2 check valve for tightness against reverse flow.

Requirement:

The valve must close tight against reverse flow under all pressure differentials.

Procedure:

1. Attach the "HIGH" hose to test cock #1 and the "LOW" hose to test cock #2.
2. Close downstream shut-off valve.
3. Open test cocks #1 and #2.
4. Open by-pass valves "C" and "A" and bleed to atmosphere until all air is expelled.
5. Close by-pass valve "A". Open by-pass valve "B" and bleed to atmosphere until all air is expelled. Close by-pass valves "B" and "C".
6. Attach the "VENT" hose to test cock #3.
7. Slowly open by-pass valves "A" and "C" and keep by-pass valve "B" closed.
8. Open test cock #3.
9. Indicated pressure differential will drop slightly. If pressure differential does not continue to decrease, the #2 check valve is considered tight.

TEST NO. 2

Purpose:

Test #1 check valve for tightness and record pressure drop across #1 check valve.

Requirement:

The static pressure drop across #1 check valve shall be greater than the relief valve opening point (test #3), and at least 35 kPa.

Procedure:

1. Close by-pass valve "A"
2. Close test cock #3, and disconnect "VENT" hose from test cock #3.
3. Open by-pass valves "B" and "C" bleeding to atmosphere, then close by-pass valve "B" restoring the system to normal static condition.
4. Observe the pressure differential gauge and note this as the #1 check valve kPa differential.

TEST NO. 3

Purpose:

To test operation of the differential relief valve.

Requirement:

The pressure differential relief valve must operate to maintain the "ZONE" between the two check valves at least 14 kPa less than the supply pressure.

Procedure:

1. Close by-pass valve "C" and open by-pass valve "A".
2. Open by-pass valve "B" very slowly until differential gauge needle starts to drop. Hold the valve at this position and observe the gauge reading at the moment the first discharge is noted from the relief valve. Record this as the opening differential pressure of the relief valve.

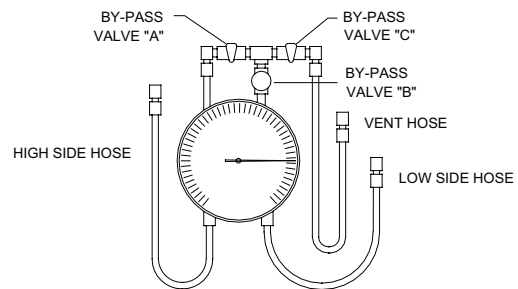
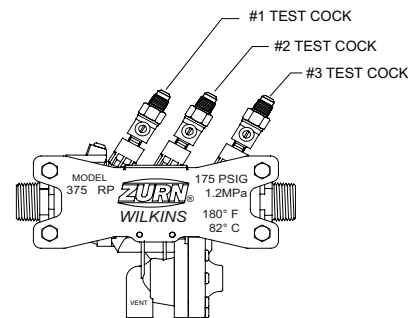

Please note all installation and testing procedures listed are intended as a guide only. Installation and testing should be in accordance to local standards and plumbing codes.

Maintenance Instructions

All Model 375 Reduced Pressure Principle Backflow Preventers must be inspected and maintained by licenced personnel at least once a year or more frequently as specified by local codes. Replacement of worn or damaged parts must only be made with genuine "WILKINS" parts. The WILKINS Certificate of Limited Warranty provides that failure to do so "...releases WILKINS of any liability that it might otherwise have with respect to that device." Such failure could also result in an improperly functioning device.

The Model 375 Reduced Pressure Principle Assemblies should be thoroughly flushed after backflow conditions occur to prevent any type of corrosive deterioration to its components. Failure to do so could result in malfunction of the device.

GENERAL MAINTENANCE

1. Clean all parts thoroughly with water after disassembly.

2. Carefully inspect rubber seal rings, diaphragms and o-rings for damage.
3. Test unit after reassembly for proper operation (see "Testing Procedures").

SERVICING CHECK VALVES

1. Close inlet and outlet shut-off valves.
2. Open #1, #2 and #3 test cocks to release pressure from valve.
3. Unscrew clamp screws and remove clamp. (Inserting screw in centre hole can remove stuck clamp). Slide sleeve toward inlet pipe. Slide valve body toward inlet and lift upward.
4. Using finger or blunt object, push in outlet end of body, both checks should slide out the body inlet. (A phillips screw driver will work in a 15-20mm valve. The closed ball valve handle will work in a 25mm valve).

5. Twist spring retainers counter-clockwise to remove from seat and access poppets.
6. Inspect the rubber seal ring for cuts or embedded debris. To remove seal ring, remove screw and seal ring retainer. If the reverse side of the seal ring is unused, it is possible to invert the seal ring. This would be considered a temporary solution to fixing a fouled check and should be replaced with a new seal ring as soon as possible.
7. Inspect seat surface for nicks or dings and replace if necessary. Use fingernail to check for dings. Re-grease seat o-rings.
8. Inspect seat o-ring sealing areas in body and wipe clean.
9. Reverse the above procedures to reinstall check valve assembly. (Drop #2 check assembly in body. Then drop #1 check assembly in and turn until #1 spring retainer lines up with #2 seat. Then push both assemblies into body.) Care should be taken to make sure the heavy spring is installed in the #1 check valve. **Do not over-tighten** clamp screws as this can cause leak at the sleeve o-ring.

SERVICING RELIEF VALVE

1. Remove relief valve cover screws and cover. Gently pull on diaphragm to remove the cartridge assembly.
2. Inspect seal ring for cuts and embedded debris. Turn over or replace if required.
3. Disassemble cartridge by unscrewing relief valve retaining screw.
4. Inspect diaphragm and o-ring for damage. Replace required parts and apply a light coat of grease to plunger o-ring, and place on plunger.
5. Carefully reassemble cartridge assembly.
6. Inspect relief valve seat for wear on seating surface. If damaged, replace seat and seat o-ring. (Twist seat and o-ring while inserting to keep it from popping out).

7. Insert cartridge assembly into relief valve cover.
8. Check cover o-ring in groove on body. Clean or replace as necessary.
9. Replace relief valve cover and cover screws.
10. Place device in service and test per "TESTING PROCEDURES".

MODEL 375 15-25mm

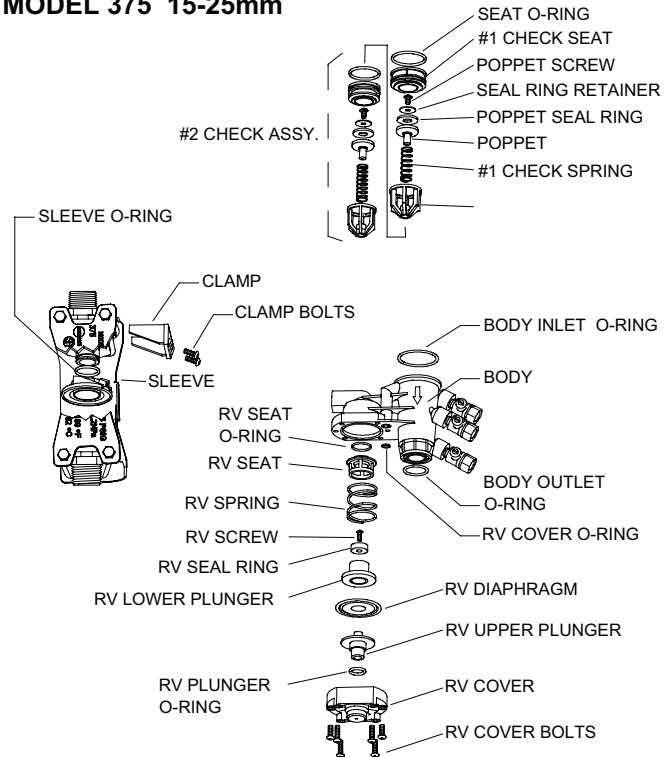

Troubleshooting

When the relief valve discharges intermittently, it can be almost always assumed that the device is functioning correctly and that the discharge is caused by system problems such as inlet pressure fluctuations or water hammer due to quick closing valves

PROBLEM

1. SUDDEN OR RAPID SPITTING

POSSIBLE CAUSES

1. Drop in inlet pressure.
2. Sudden increase in downstream pressure due to water hammer from quick closing shut-off valve installed downstream.

CORRECTIVE ACTION

- A. Install an in-line spring loaded check valve upstream of backflow.
- B. Install pressure reducing valve upstream of backflow unit.
- C. Install in-line spring loaded check valve downstream of backflow as close to source as possible, but not closer than 1.2m.

2. LIGHT INTERMITTENT DRIP

1. Slightly fouled #1 check.

- A. Clean #1 check and turn check valve seal ring over or replace.

Continuous discharge of the relief valve signifies a failure of some part of the device. To help determine the specific area of failure, close the #2 shut-off valve. If the discharge stops, the #2 check requires service. If the discharge continues, the #1 check requires service.

1. CONTINUOUS DISCHARGE

1. Fouled #1 check.
2. Fouled relief valve seat.
3. Fouled #2 check.

- A. Clean check valves and turn check valve seal rings over or replace.
- B. Clean relief valve seat and turn relief valve seal ring over or replace.

In summary, the amount of discharge is proportional to degree of fouling. Most problems occur in the #1 check which is where debris enters the backflow preventer first.

Proper performance is dependent upon licenced, qualified personnel performing regular, periodic testing according to WILKINS' specifications and prevailing governmental and industry standards and codes and upon following these installation instructions. Failure to do so releases WILKINS of any liability that it might otherwise have with respect to that device. Such failure could also result in an improperly functioning device.

SPECIFICATIONS

Maximum working water pressure	1200 kPa
Maximum working water temp.	82°C
Hydrostatic test pressure	2400 kPa
End connections	ISO 7.1 R
	Tapered Pipe Thread

Blow Out / Flush Procedure for Freeze Protection

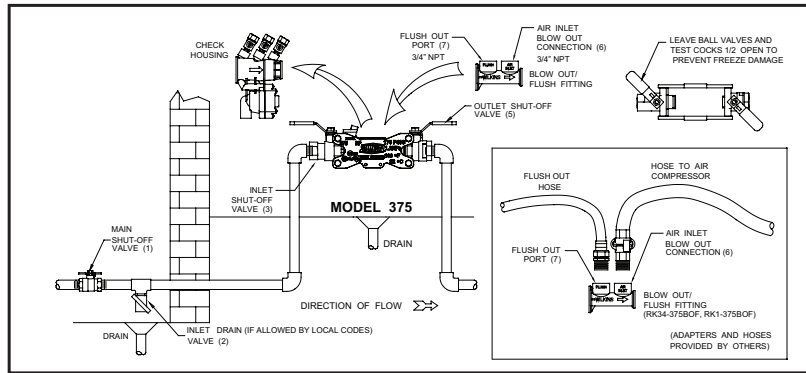

To blow out system for freeze protection, use the following procedure:

1. Turn off main shut-off valve (1) that supplies water to the system.
2. Open inlet drain valve in the system (2). Open inlet and outlet shut-off valves on the backflow preventer (3 & 5) and all of the test cocks (4). Leave all valves and test cocks in the half open/half closed (45°) position to allow full drainage of the ball valves and test cocks.
3. Remove black backflow preventer housing. Replace with orange Blow Out / Flush Fitting. Store backflow preventer housing in a safe location for winter. Orange Blow Out / Flush Fitting may remain in valve body during winter. Place plugs in ports to keep debris from entering housing.
4. A hose and adapter can be connected to flush out port (7) to drain water to a safe drain.
5. Connect an air hose and adapter to the air inlet connection (6). Inject an adequate volume of air to remove all water from the downstream portion of the system. Do not allow the fitting to overheat.
6. Leave drain valve (2), shut-off valves (3 & 5) and test cocks (4) in the half open/half closed position (45°) for the duration of the winter to prevent freezing.
7. Store valve body/check assemblies, clamp/sleeve and o-rings in bag during winter to prevent weathering.

To flush system during installation, use the following procedures:

1. Install backflow device in pipe system, leave water off.
2. Remove the black backflow preventer housing from the brass body.
3. Install the orange Blow Out / Flush Fitting into the brass body.
4. Thread a garden hose adapter into flush-out port (7). Connect a hose to the adapter and run to a safe drain. Shut-off valves (3) and (4) should be open.
5. Turn on water supply at main shut-off valve (1) to flush out any debris in the pipe. Turn water off.
6. Remove orange Blow-Out / Flush Fitting and replace black check housing back into the line. Close shut-off valves (3) and (4). Turn water on at main shut-off (1).
7. Slowly open shut-off valve (3) to pressurize backflow preventer. Once fully open, pressurize system by slowly opening shut-off valve (4).

CAUTION: For freeze protection, be certain that main shut-off valve (1) remains tightly closed to prevent refilling of the system. Also, the main shut-off valve must be resilient seated to ensure no leakage of water into the system.

Performance Characteristics

Relief Valve Discharge Rates

(Worst case condition - if 1st check or relief valve is lodged wide open)

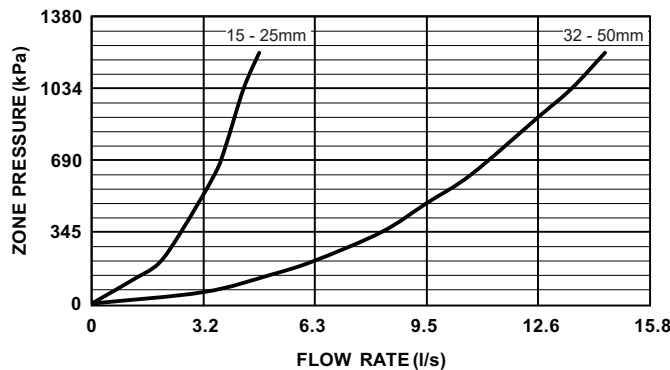

Capacity through Schedule 40 Pipe (l/s)				
Pipe size (mm)	1.5 (m/s)	2.3 (m/s)	3.0 (m/s)	4.6 (m/s)
15	0.3	0.4	0.6	0.9
20	0.5	0.8	1.1	1.6
25	0.8	1.3	1.7	2.5
32	1.5	2.2	3.0	4.4
40	2.0	3.0	4.0	6.0
50	3.3	4.9	6.6	10.5

REPAIR KITS FOR 375's	
BLOW OUT/FLUSH FITTING 15-20mm RK34-375BOF 25mm RK1-375BOF	 BLOW OUT/ FLUSH FITTING
COMPLETE INTERNALS 15-20mm RK34-375 (180415) 25mm RK1-375 (180455)	WEDGE/CLAMP 15-20mm RK34-375W (180420) 25mm RK1-375W (4000388)
RUBBER PARTS 15-20mm RK34-375R (180416) 25mm RK1-375R (180425)	VESSEL 15-20mm RK34-375V (180459) 25mm RK1-375V (180464)