

# WILKINS® Backflow Prevention

350, 350A & 350DA Series DCV

65-250mm

## Installation, Testing & Maintenance

### INSTALLATION INSTRUCTIONS

**CAUTION:** Installation of Backflow Preventers must be performed by qualified, licenced personnel. The installer should be sure the proper device has been selected for the particular installation. Faulty installation could result in an improperly functioning device.

WILKINS Model 350 Series Assemblies are for use on potable water lines where a medium health hazard exists in the event of a backflow situation.

Damage to the device could result wherever water hammer and/or water thermal expansion could create excessive line pressure. Where this could occur, shock arrestors, check valves and/or pressure relief valves should be installed downstream of the device.

If installation is in a pit or vault, the Backflow Preventer must never be submerged in water because this could cause a cross-connection. Make sure that the pit or vault always remains dry by providing ample drainage.

1. Before installing a Model 350 Series Backflow Preventer, flush the line thoroughly to remove all debris, chips and other foreign matter. If required, a strainer should be placed upstream of the Backflow Preventer.

**CAUTION:** Do not use a strainer in seldom used emergency waterlines such as fire lines.

2. Provide adequate space around the installed unit so that the test cocks will be accessible for testing and servicing.
3. Install valve at least 305mm above surrounding flood level.
4. Always consult local codes for installation methods, approvals and guidance.

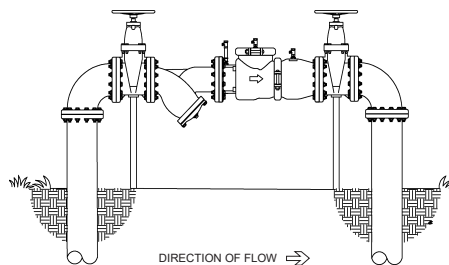

**OUTDOOR INSTALLATION**  
Model 350

### OUTDOOR INSTALLATION

The Model 350 Series Backflow Preventer may be installed outdoors only if the device is protected against freezing conditions. Exposure to freezing conditions will result in improper function or damage to the device. The installation location must be kept above 0°C. All the basic installation instructions apply.

### PLACING THE DEVICE IN SERVICE

1. Start with both shut-off valves closed. Slowly open the inlet shut-off valve until the backflow preventer is completely pressurised.
2. When the unit has been pressurised, vent any trapped air by slightly opening each of the four test cocks.
3. Slowly open the downstream shut-off valve. The Model 350 Series Assembly is now in service.
4. After the Model 350 Series has been properly installed, test the device (see "TEST PROCEDURES"). If the device fails the test, remove the first and second check valves and thoroughly flush the device. Clean rubber and seats of all debris and place unit back in service.

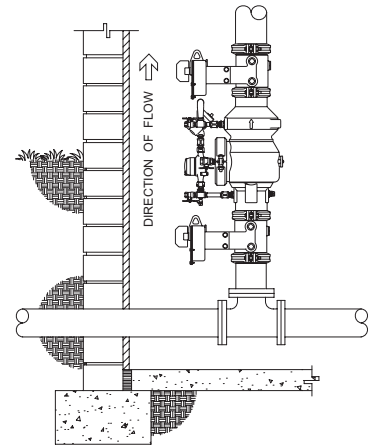

**INDOOR INSTALLATION**  
Model 350DA

### INDOOR & VERTICAL INSTALLATION

Indoor installation is preferred in areas that are subject to freezing conditions. All the basic installation instructions apply to such installations.

Vertical installation is acceptable in applications where inlet and outlet piping are flowing vertically upwards. All the basic installation instructions apply to such installations.

# Testing Procedures

## MODEL 350 SERIES ASSEMBLY

Equipment Required: Differential pressure gauge test kit.

### TEST NO. 1 - TIGHTNESS OF #1 CHECK VALVE

#### REQUIREMENT:

The static pressure drop across check valve #1 shall be at least 7 kPa. If test cock #3 is not at the highest point of the check valve body, then a vertical tube must be installed on test cock #3 so that it rises to the top of the check valve body.

#### PROCEDURE:

1. Slowly open all 3 test cocks to remove any foreign material and attach fittings.
2. Attach hose from the high side of the test kit to the #1 test cock.
3. Open test cock #1 and bleed all air from the hose and gauge by opening the high side bleed needle valve. Close high side bleed needle valve. Close #2 shut-off valve then close the #1 shut-off valve.
4. Hold gauge at same level as test cock #2. Slowly open test cock #2. Record the static pressure drop across check valve #1 after gauge reading stabilises and water stops running out of test cock #2.
5. Close all test cocks, open shut-off valve #1 and remove test equipment.

**Note:** If you are using the duplex gauge method to test the valve, you may see both needles drop simultaneously during test due to disc compression. The high side needle should eventually hold 14 kPa below low side needle if check is not fouled.

Please note all installation and testing procedures listed are intended as a guide only. Installation and testing should be in accordance to local standards and plumbing codes.

### TEST NO. 2 - TIGHTNESS OF #2 CHECK VALVE

#### REQUIREMENT:

The static pressure drop across check valve #2 shall be at least 7 kPa.

#### PROCEDURE:

1. Attach hose from the high side of the test kit to the #2 test cock.
2. Open test cock #2 and bleed all air from the hose and gauge by opening the high side bleed needle valve. Close high side bleed needle valve. Close #1 shut-off valve.
3. Hold gauge at same level as test cock #3 or water level in tube. Slowly open test cock #3. Record the static pressure drop across check valve #2 after gauge reading stabilises and water stops running out of test cock #3.
4. Close all test cocks, slowly open shut-off valve #1 & #2 and remove test equipment.

#### BYPASS (DDCV ONLY):

If the reading of the bypass valve is equal or greater than the main valve, the main valve shall be repaired or replaced. The test shall be repeated. Refer to AS/NZS 2845 for more information.

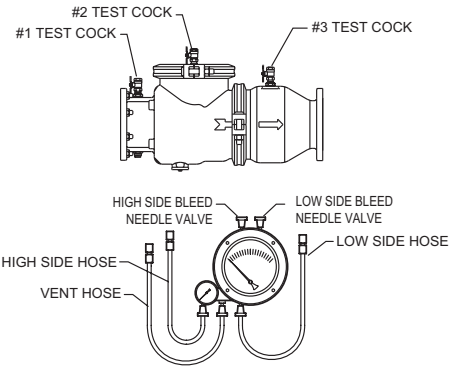

## Repair Kits

SIZE	MODEL 350/350DA RUBBER ONLY (ZURN CODES & REECE CODES)
65-80mm	RK212-350 (180436)
100mm	RK4-350 (1000888)
150mm	RK6-350 (180414)

## Maintenance Instructions

### CHECK ASSEMBLY

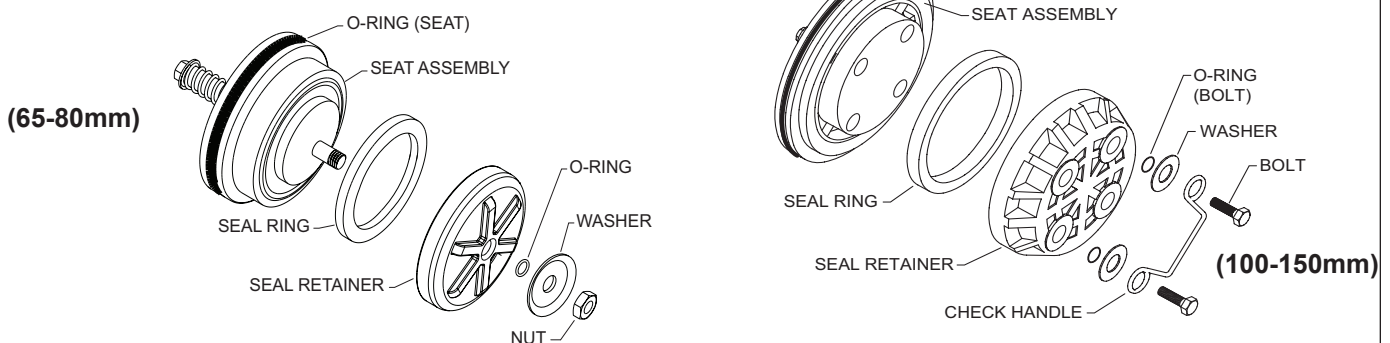

All Model 350 Series Backflow Preventers must be inspected and maintained by an accredited backflow prevention tester at least once a year or more frequently as specified by local codes. Replacement of worn or damaged parts must only be made with genuine "WILKINS" parts.

**GENERAL MAINTENANCE**

1. Clean all parts thoroughly with water after disassembly.
2. Carefully inspect rubber seal rings and o-rings for damage.
3. Test unit after reassembly for proper operation (refer to "TESTING PROCEDURES").

NOTE: If any portion of the seat assembly is damaged or missing or if the seating surface is damaged in any way, do not attempt to field repair it. Contact your local Reece branch for assistance.

**SERVICING CHECK VALVES**

1. Close the outlet and then the inlet shut-off valves.
2. Open No. 1, 2 and 3 test cocks to release internal pressure. Leave them open during check removal and reinstallation.
3. Loosen and remove the two nuts, bolts and gasket from the grooved coupling around the access cover.
4. If the valve has a wire retainer on the #1 check assembly, pinch together the exposed ends, pull toward the #2 check and remove from valve.
5. If the valve has a plastic retainer on the #1 check, grasp one of the exposed ends, push down and then pull toward the #2 check. The retainer should "spiral" out of the groove around the check.
6. (65-80mm Models) Remove the #2 retainer and check in the same manner as the #1.  
(100-150mm Models) Remove the #2 check by locating one of the two spring-loaded plate retainers around the face of

the check. Pinch the sides of the spring together and rotate the plates out of the body groove one at a time. Remove the 2nd retainer the same way.

7. **Always service the checks one at a time to avoid mixing parts.** Start by removing the hardware and o-rings from the back of the check assembly (See "Check Assembly" illustration). Separate the seal retainer from the assembly to expose the seal ring.
8. Inspect the seal ring for cuts or embedded debris. If the reverse side of the seal is unused, the seal ring can be inverted and used temporarily until a new seal is obtained. (65-80mm Models) Tighten check assembly nut to no greater than 33.9 Nm. Inspect seat o-ring and replace if cut or damaged in any way.
9. Inspect valve cavity and seating areas. Flush with water to remove any debris.
10. (Reassembly, 65-80mm Models) Lubricate the #2 check o-ring, install in the body and close the #3 test cock to hold it in place. Install the plastic retainer by inserting one end into the body groove and then sliding your hand around the face of the retainer, pushing it into the groove as you go. The retainer will "snap" into place when fully seated. Install #1 check and retainer in the same way.  
(Reassembly, 100-150mm Models) Lubricate the #2 check o-ring, install in the body and close the #3 test cock. Install the #2 check retainers into the body groove one plate at a time, squeezing the spring ends together to clear the stops on the face of the seat. Lubricate and install the #1 check, close the #2 test cock and install:  
(A) wire retainer by pinching the ends together, placing the lower edge of the ring into the body groove below the check and rotating the top of the ring into the notch above the check.  
(B) plastic retainer as described above in the 65-80mm Models Reassembly section.
11. Lubricate the outside surface of the grooved coupling gasket. Reassemble access cover and grooved coupling, making sure the ends of the coupling touch each other. Close any remaining open test cocks and place valve back in service.

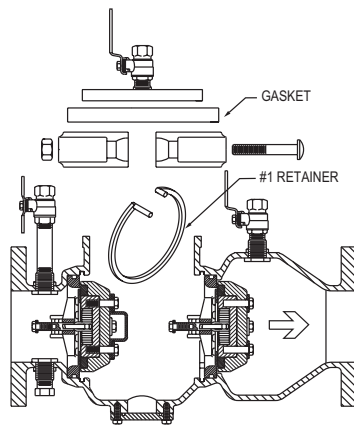

FIGURE 1

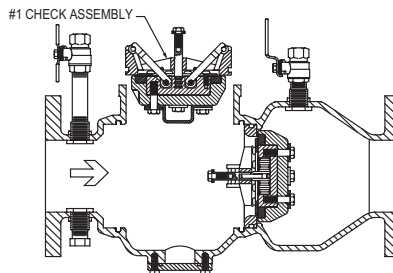

FIGURE 2

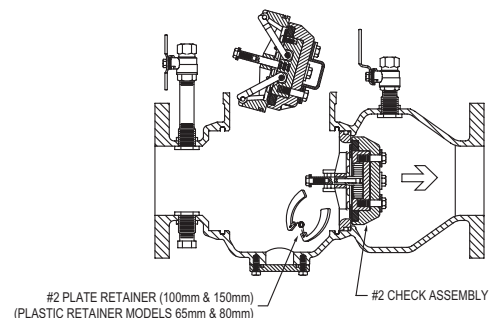

FIGURE 3

**Troubleshooting**

PROBLEM

1. LEAKING CHECK VALVES
2. LOW OR NO FLOW

POSSIBLE CAUSES

1. Debris on seat or seal ring
2. Damaged seat area
3. Damaged seat o-ring
4. Damaged bolt o-ring (s) on check retainer
1. Device installed backwards
2. Isolation valves not fully open
3. Low supply pressure

CORRECTIVE ACTION

1. Clean seat area
2. Replace check assembly
2. Replace seat o-ring
4. Replace o-ring (s)
1. Verify flow direction arrow
2. Turn handles counterclockwise
3. Attach pressure gauge to test cock #1 and verify pressure

# Performance Characteristics

**MODEL 350/ 350A 65mm, 80mm & 100mm (STANDARD & METRIC)**

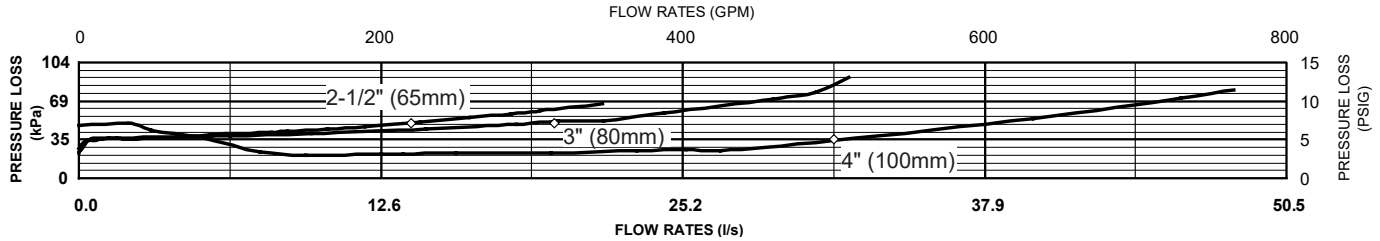

**MODEL 350/ 350A 150mm & 200mm (STANDARD & METRIC)**

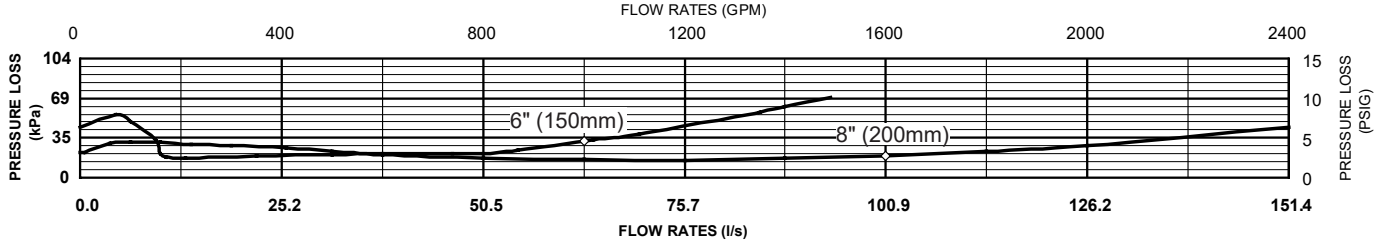

**MODEL 350DA 65mm, 80mm & 100mm (STANDARD & METRIC)**

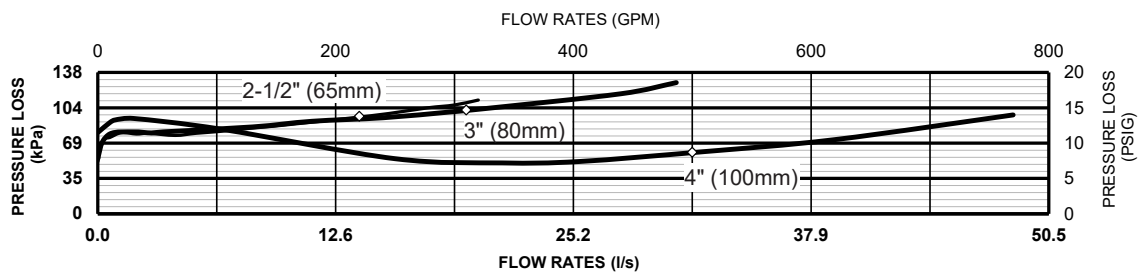

**MODEL 350DA 150mm, 200mm & 250mm (STANDARD & METRIC)**

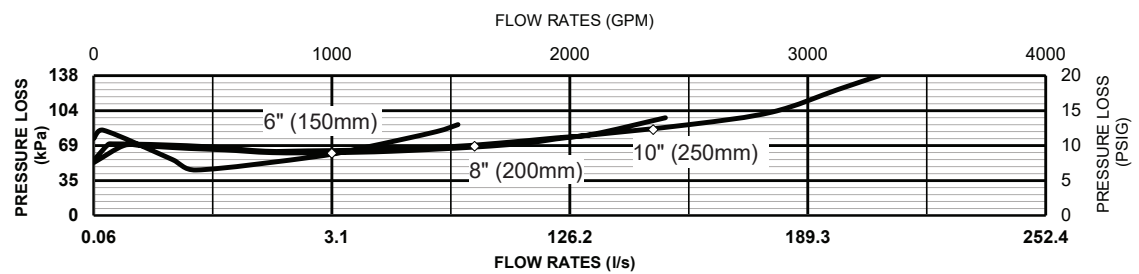

◇ Rated Flow (established by approval agencies)

Capacity through Schedule 40 Pipe (l/s)				
Pipe size (mm)	1.5 (m/s)	2.3 (m/s)	3 (m/s)	4.6 (m/s)
65	4.7	7.1	9.4	14.1
80	7.3	10.9	14.5	21.8
100	12.5	18.8	25.0	37.5
150	28.4	42.6	56.8	85.2
200	49.2	73.8	98.4	147.6
250	77.5	116.3	155.1	232.6

## SPECIFICATIONS

Maximum working water pressure: 1200 kPa  
 Maximum working water temperature: 60°C  
 Hydrostatic test pressure: 2400 kPa  
 End connections: Flanged AS 2129 TABLE E (350 & 350DA)  
 Grooved, AWWA C606 (350A)

Proper performance is dependent upon licenced, qualified personnel performing regular, periodic testing according to WILKINS' specifications and prevailing governmental and industry standards and codes and upon following these installation instructions. Failure to do so releases WILKINS of any liability that it might otherwise have with respect to that device. Such failure could also result in an improperly functioning device.