

This product complies with the lead-free requirements of NCC vol 3

Installation, Testing & Maintenance

INSTALLATION INSTRUCTIONS

CAUTION: Installation of Backflow Preventers must be performed by qualified, licenced personnel. The installer should be sure the proper device has been selected for the particular installation. Faulty installation could result in an improperly functioning device.

ZURN WILKINS Model 350 Double Check Valve assemblies are for use on water lines where a health hazard does not exist in the event of a backflow situation.

Damage to the device could result wherever water hammer and/or water thermal expansion could create excessive line pressure. Where this could occur, shock arresters, check valves and/or pressure relief valves should be installed downstream of the device.

If installation is in a pit or vault, the Backflow Preventer must never be submerged in water because this could cause a cross-connection. Make sure that the pit or vault always remains dry by providing ample drainage.

1. Before installing a Model 350 Backflow Preventer, flush the line thoroughly to remove all debris, chips and other foreign matter. If required, a strainer should be placed upstream of the Backflow Preventer. **CAUTION:** Do not use a strainer in seldom used emergency waterlines such as fire lines.
2. Provide adequate space around the installed unit so that the test cocks will be accessible for testing and servicing.
3. Install valve at least 305mm above surrounding flood level.
4. Always consult local codes for installation methods, approvals and guidance.

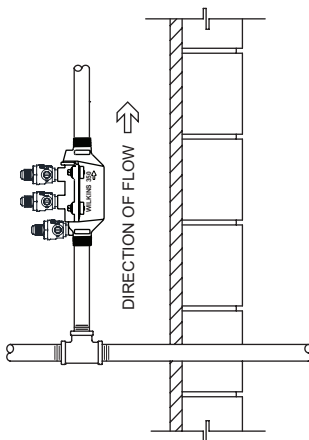

VERTICAL INSTALLATION

Vertical installation is acceptable in applications where inlet and outlet piping are flowing vertically upwards. All the basic installation instructions apply to such installations. Consult asset owner for approval status.

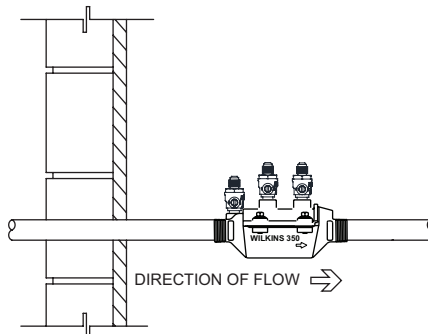

INDOOR INSTALLATION

Indoor installation is preferred in areas that are subject to freezing conditions. All the basic installation instructions apply to such installations.

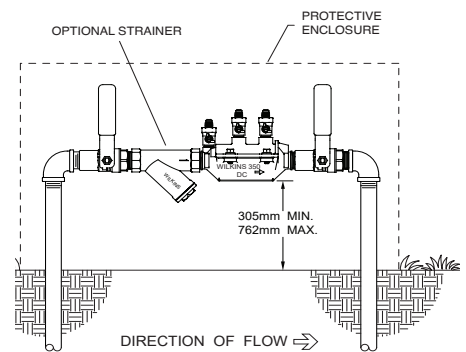
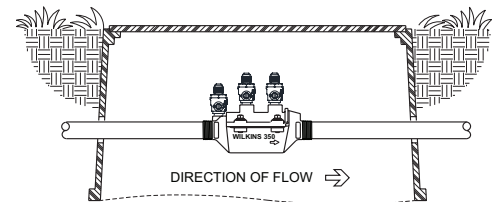

OUTDOOR INSTALLATION

The Model 350 Backflow Preventer may be installed outdoors only if the device is protected against freezing conditions. Exposure to freezing conditions will result in improper function or damage to the device. The installation location must be kept above 0°C. All the basic installation instructions apply.

PLACING THE MODEL 350 IN SERVICE

1. Start with both shut-off valves closed. Slowly open the inlet shut-off valve until the backflow preventer is completely pressurised.
2. When the unit has been pressurised, vent any trapped air by slightly opening each of the four test cocks.
3. Slowly open the downstream shut-off valve. The Model 350 Double Check Valve assembly is now in service.
4. After the Model 350 has been properly installed, test the device (see "TEST PROCEDURES"). If the device fails the test, remove the first and second check valves and thoroughly flush the device. Clean rubber and seats of all debris and place unit back in service.

Testing Procedures

MODEL 350 DOUBLE CHECK VALVE ASSEMBLY

Equipment Required: Differential pressure gauge test kit.

TEST NO. 1 - TIGHTNESS OF #1 CHECK VALVE

REQUIREMENT:

The static pressure drop across check valve #1 shall be at least 7 kPa. If test cock #3 is not at the highest point of the check valve body, then a vertical tube must be installed on test cock #3 so that it rises to the top of the check valve body.

PROCEDURE:

1. Slowly open all 3 test cocks to remove any foreign material and attach fittings.
2. Attach hose from the high side of the test kit to the #1 test cock.
3. Open test cock #1 and bleed all air from the hose and gauge by opening the high side bleed needle valve. Close high side bleed needle valve. Close #2 shut-off valve then close the #1 shut-off valve.
4. Hold gauge at same level as test cock #2. Slowly open test cock #2. Record the static pressure drop across check valve #1 after gauge reading stabilizes and water stops running out of test cock #2.
5. Close all test cocks, open shut-off valve #1 and remove test equipment.

TEST NO. 2 - TIGHTNESS OF #2 CHECK VALVE

REQUIREMENT:

The static pressure drop across check valve #2 shall be at least 7 kPa.

PROCEDURE:

1. Attach hose from the high side of the test kit to the #2 test cock.
2. Open test cock #2 and bleed all air from the hose and gauge by opening the high side bleed needle valve. Close high side bleed needle valve. Close #1 shut-off valve.
3. Hold gauge at same level as test cock #3. Slowly open test cock #3. Record the static pressure drop across check valve #2 after gauge reading stabilizes and water stops running out of test cock #3.
4. Close all test cocks, slowly open shut-off valve #1 & #2 and remove test equipment.

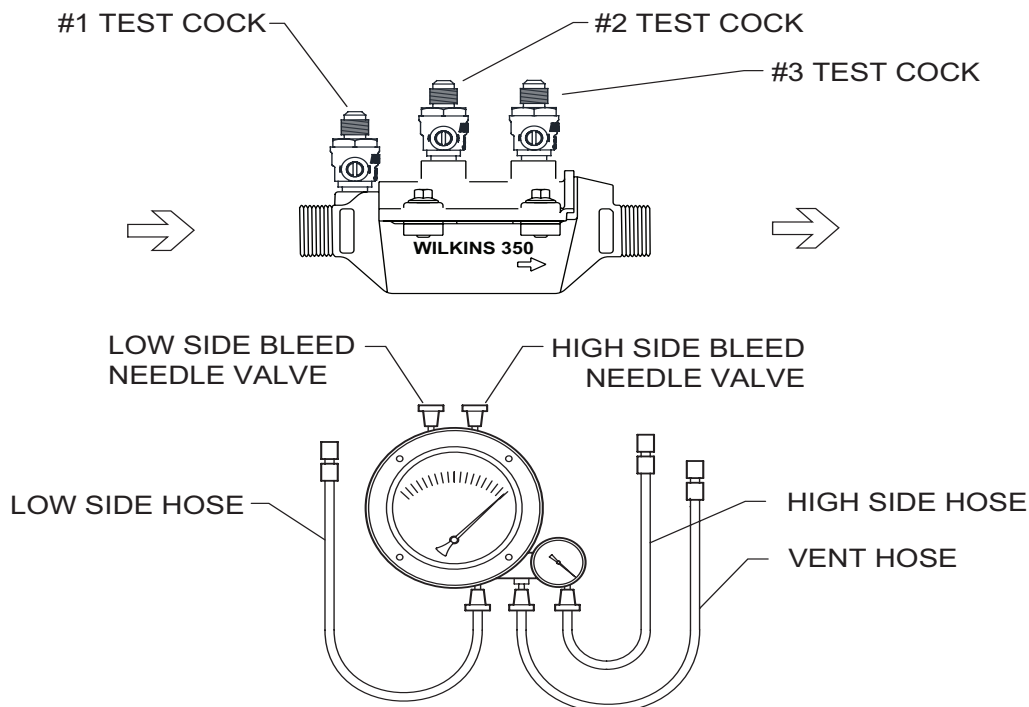

Please note all installation and testing procedures listed are intended as a guide only. Installation and testing should be in accordance to local standards and plumbing codes.

Maintenance Instructions

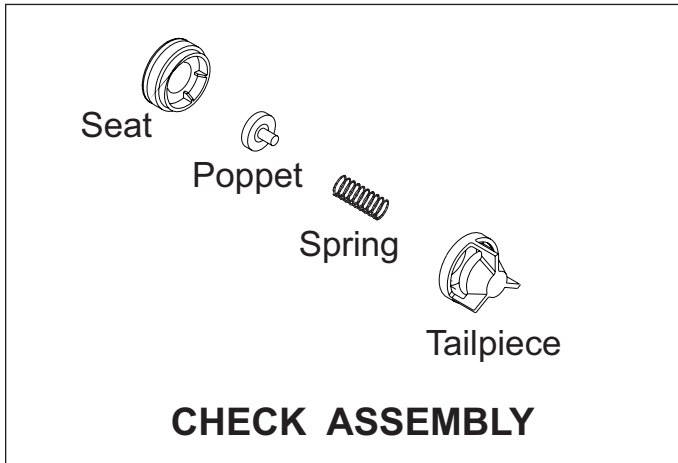

All Model 350 Double Check Valve Backflow Preventers must be inspected and maintained by licenced personnel at least once a year or more frequently as specified by local codes. Replacement of worn or damaged parts must only be made with genuine "ZURN WILKINS" parts.

GENERAL MAINTENANCE

1. Clean all parts thoroughly with water after disassembly.
2. Carefully inspect rubber seal rings and o-rings for damage.
3. Test unit after reassembly for proper operation (refer to "TESTING PROCEDURES").

SERVICING CHECK VALVES

1. Close inlet and outlet shut-off valves.
2. Open #1, #2 and #3 test cocks to release pressure from valve.
3. Unscrew the 4 bolts (1/4-20 UNC Hex Flange) holding the housing in place.
4. Using a #2 flathead screwdriver, pry loose housing by placing the screwdriver in the notch between housing and body.
5. Pull housing out of the body and remove checks by sliding them towards the outlet of housing.
6. Using the same screwdriver, locate the notch between seat and tailpiece of each check. Insert screwdriver and twist to "snap" checks apart. CAUTION: Checks are spring loaded.
7. Inspect the rubber seal ring around poppet for cuts or embedded debris.
8. If the poppet is damaged, replace with a new poppet.
9. Inspect the remaining check parts and seating areas. Remove any debris.
10. If necessary, replace any damaged parts with new ones.
11. Lightly grease o-rings on checks and reinstall into housing following the above procedures in reverse order.
12. Flush body prior to reinstalling housing.
13. Lightly grease o-rings on housing and reinstall into body following the above procedures in reverse order.

Note: When installing housing, match slight taper on the outlet of the housing with corresponding taper in body.

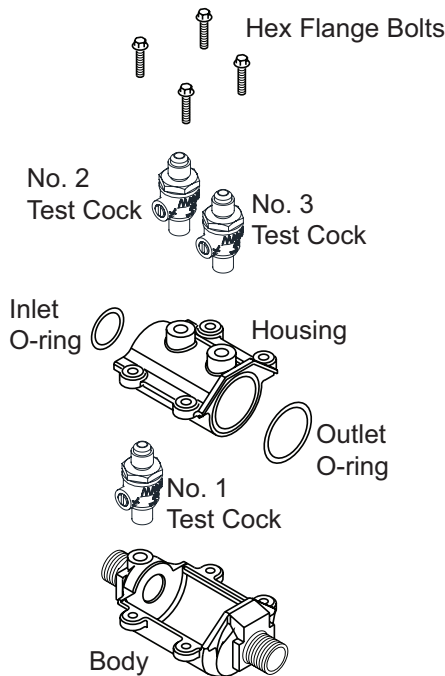

FIGURE 1

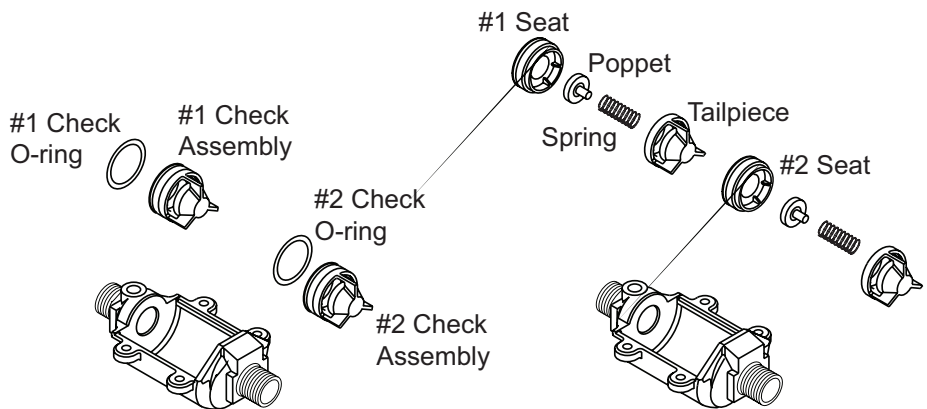

FIGURE 2

FIGURE 3

Troubleshooting

PROBLEM

POSSIBLE CAUSES

CORRECTIVE ACTION

1. LEAKING CHECK VALVES

1. Debris on seat or seal ring
2. Damaged seat
3. Damaged seal ring
4. Damaged check o-ring

1. Clean seat and seal ring area
2. Replace seat
3. Replace poppet
4. Replace check o-ring

2. LOW OR NO FLOW

1. Device installed backwards
2. Shut-off valves or valve upstream may not be fully open
3. Low supply pressure

Performance Characteristics

FLOW CHARACTERISTICS

MODEL 350 20-25mm (STANDARD & METRIC)

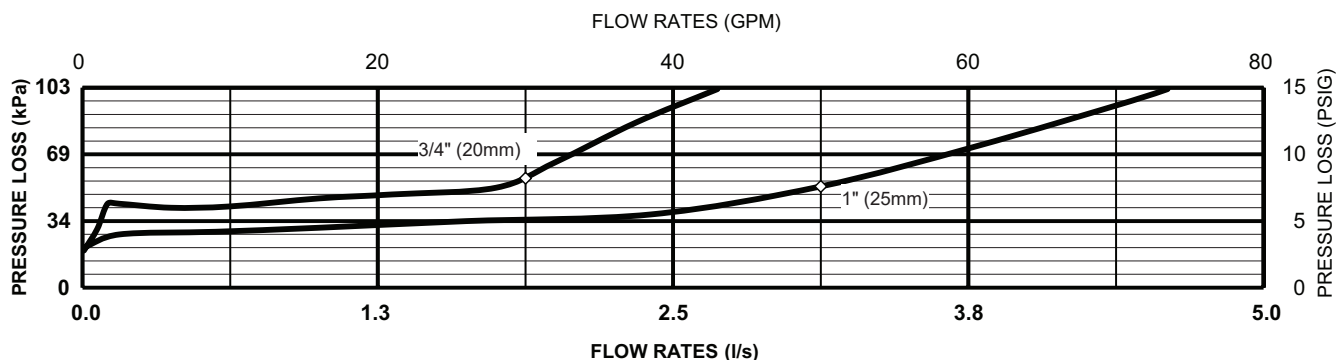

◇ Rated Flow (Established by approval agencies)

Capacity through Schedule 40 Pipe (l/s)

Pipe size (mm)	1.5 (m/s)	2.3 (m/s)	3.0 (m/s)	4.6 (m/s)
15	0.3	0.4	0.6	0.9
20	0.5	0.8	1.1	1.6
25	0.8	1.3	1.7	2.5
32	1.5	2.2	3.0	4.4
40	2.0	3.0	4.0	6.0
50	3.3	4.9	6.6	10.5

SPECIFICATIONS

Maximum working water pressure	1200 kPa
Maximum working water temperature	82°C
Hydrostatic test pressure	2400 kPa
	ISO 7.1 R
End connections	Tapered Pipe Thread

Proper performance is dependent upon licenced, qualified personnel performing regular, periodic testing according to ZURN WILKINS' specifications and prevailing governmental and industry standards and codes and upon following these installation instructions. Failure to do so releases ZURN WILKINS of any liability that it might otherwise have with respect to that device. Such failure could also result in an improperly functioning device.